

TRANSPORT PACKAGING SOLUTIONS

FlexProfile

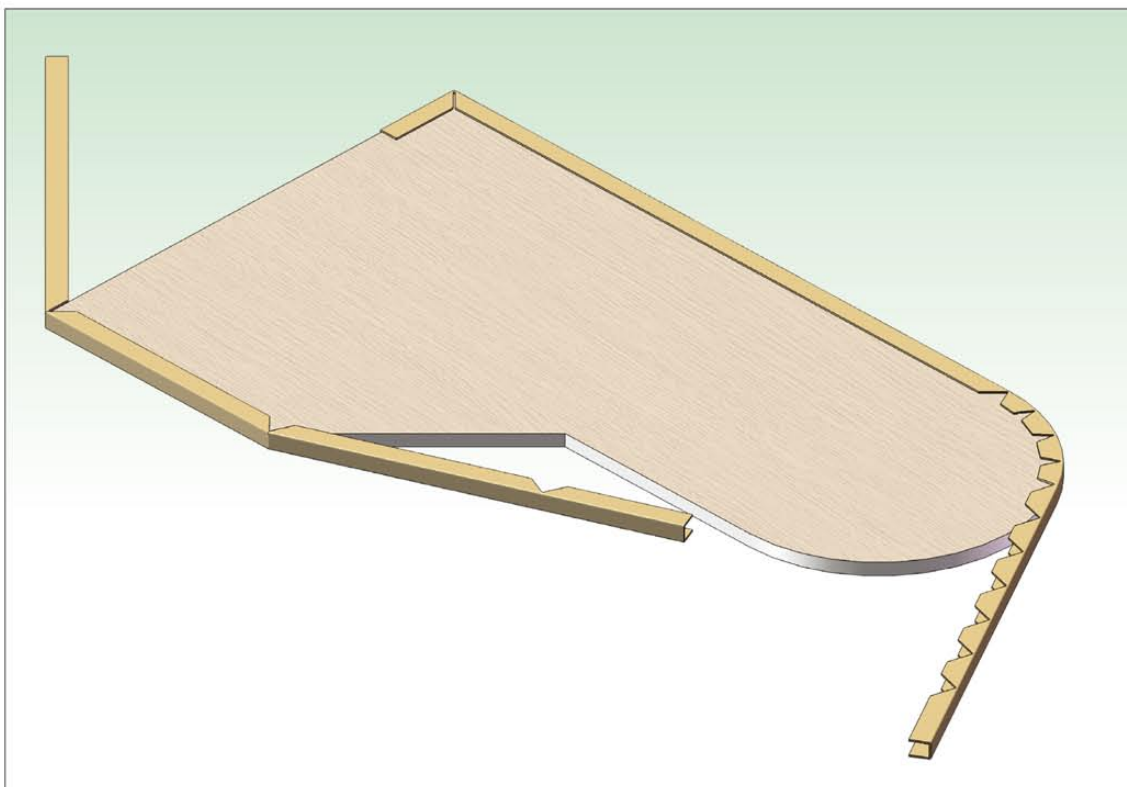

Tailor-made protection with compact carton board



- Flexible for any form
- Available as U-profile
- 100 % carton board
- Easy recycling
- Environmentally friendly transport packaging



Sustainable packaging is your contribution to the environment

TRANSPORT PACKAGING SOLUTIONS

FlexProfile



Tailor-made protection with compact carton board



FlexProfile can be tailor-made according to the size of the protected product.

FlexProfile gives you high protection for impacts and transport damage.



Advantages:

- Gives strong protection
- Light
- Less material
- Easy to use
- Easy to dispose of
- Environmentally friendly
- Gives good company image

Savings in:

- Warehousing
- Material costs
- Recycling costs
- Transport costs

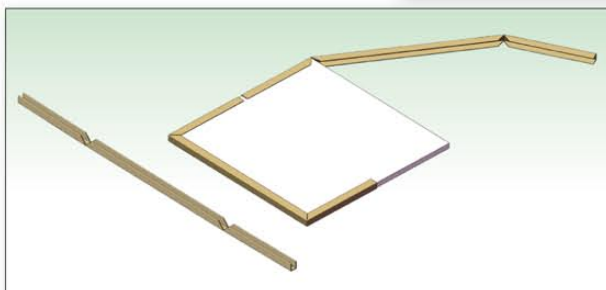
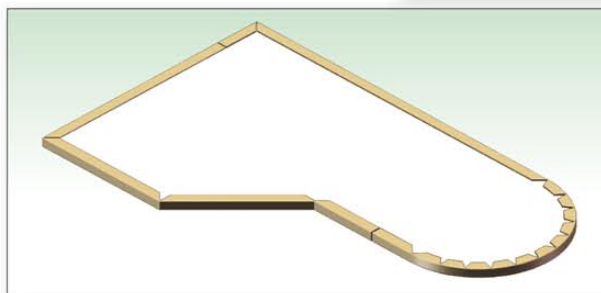
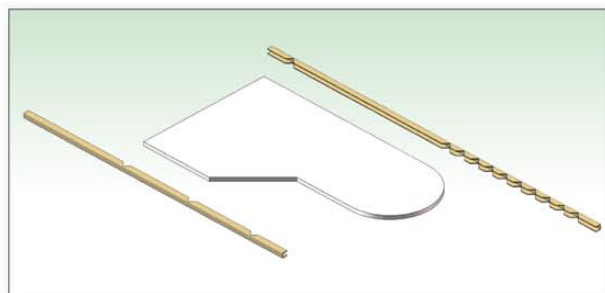

TRANSPORT PACKAGING SOLUTIONS

FrameBox



Combines light weight with strength!

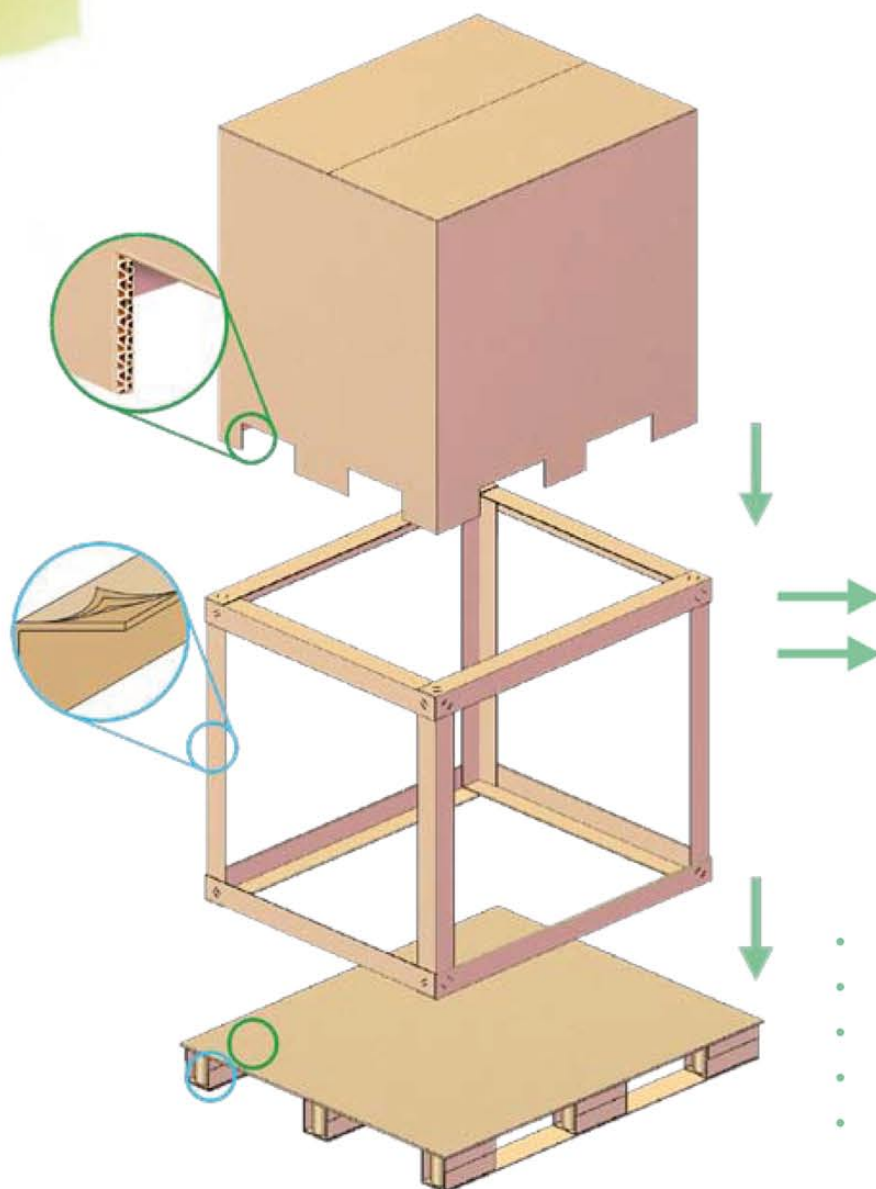

FrameBox is a combination of a Carton Board Pallet, FramePack corrugated board box and strapping.

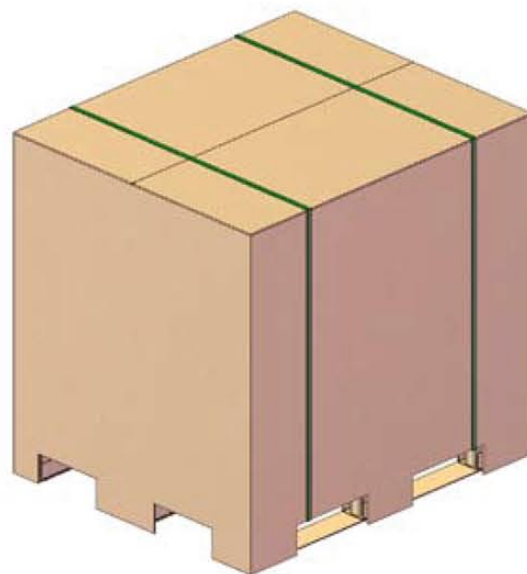

- Single-material packaging solution
- 100 % carton board
- More stacking strength
- Simple assembly
- Accepted anywhere in the world without treatment or restrictions.



Sustainable packaging is your contribution to the environment

TRANSPORT PACKAGING SOLUTIONS

FrameBox



Combines light weight with strength!



FramePack * stabilises and gives good stacking strength. High-quality edgeboards can be chosen according to the needs of each individual packaging process.

PallRun * in combination with corrugated or honeycomb board makes a strong carton board pallet.

PallRun * is made out of laminated compact carton board (U-profiles) and stabilisation elements (cores). The U-profile is reinforced by wet strengthened kraftliner giving high protection for humidity.

Flatboard is often added to 4-way pallets in order to strengthen the base and to make it suitable for roll conveyer use.



A corrugated board box on top of the FramePack completes the final protection for the packaging unit.

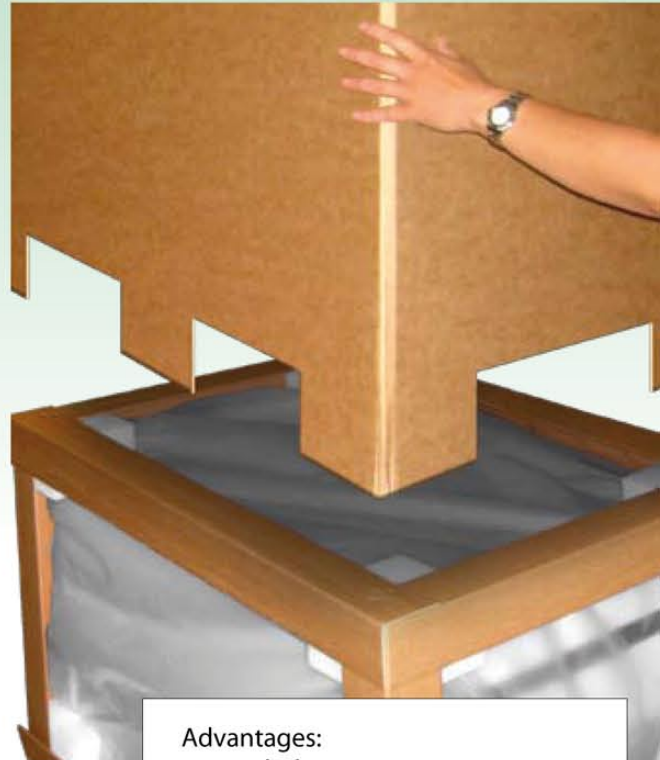

Advantages:

- Light but strong
- Less material
- No bulky pallets needed
- Easy to use
- Easy to dispose of
- Environmentally friendly
- Needs no treatment like wood
- Gives good company image

Savings in:

- Warehousing
- Material costs
- Recycling costs